

77.694 ACRES
VERA LUCILLE JINKS
VOLUME 1102, PAGE 752
D.R.C.C.T.

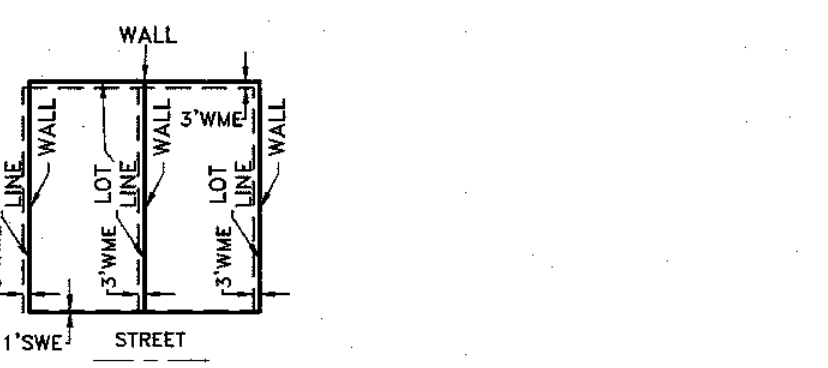

**A FINAL PLAT
OF
HILLSIDE VILLAGE,
PHASE 1A
OUT OF THE
COLLIN COUNTY SCHOOL
LAND SURVEY NO. 14,
ABSTRACT NO. 167
IN THE
CITY OF CELINA, COLLIN COUNTY, TEXAS**

**66.828 ACRES
256 RESIDENTIAL LOTS
11 OPEN SPACE/HOA LOTS**

SHEET 1 OF 2

LEGEND

CIRF CAPPED IRON ROD FOUND
IRF IRON ROD FOUND
AE ACCESS EASEMENT
LSE LANDSCAPE EASEMENT/SIDEWALK EASEMENT
UE UTILITY EASEMENT
DE DRAINAGE EASEMENT
WE WATER LINE EASEMENT
WLE WATERLINE EASEMENT
WWE WATER WASTE EASEMENT
O.E. ONCOR EASEMENT

D.R.C.C.T. DEED RECORDS, COLLIN COUNTY, TEXAS
O.P.R.C.C.T. OFFICIAL PUBLIC RECORDS, COLLIN COUNTY, TEXAS
P.R.C.C.T. PLAT RECORDS, COLLIN COUNTY, TEXAS
(RM) RECORD MONUMENT
(CM) CONTROLLING MONUMENT
STREET NAME CHANGE

NOTES:

- BEARING BASIS IS BASED ON GRID NORTH, TEXAS STATE PLAN COORDINATES, NORTH CENTRAL ZONE NAD83 (2011) EPOCH 2010, DETERMINED BY GPS OBSERVATIONS, CALCULATED FROM COLLIN CORE ARP (P01-078982), AND DENTON CORE ARP (P01-078986).
- FLOOD ZONE DESIGNATION FROM FEDERAL EMERGENCY MANAGEMENT AGENCY FLOOD INSURANCE RATE MAP, COMMUNITY PANEL NO. 4805C0110J WITH AN EFFECTIVE DATE OF JUNE 2, 2009, AND PANEL NO. 4805C0120J, WITH AN EFFECTIVE DATE OF JUNE 2, 2009. SUBJECT TRACT LIES WITHIN ZONE X DEFINED AS AREAS DETERMINED TO BE OUTSIDE 500-YEAR FLOODPLAIN.
- ALL LOTS COMPLY WITH THE MINIMUM SIZE REQUIREMENTS OF THE ZONING DISTRICT AND BUILDING SETBACK REQUIREMENTS PER HILLSIDE VILLAGE DEVELOPMENT AGREEMENT (CC # 021080501584000 O.P.R.C.C.T.).

- THIS PROPERTY MAY BE SUBJECT TO CHARGES RELATED TO IMPACT FEES AND THE APPLICANT SHOULD CONTACT THE CITY REGARDING ANY APPLICABLE FEES DUE.
- ALL COMMON AREAS, DRAINAGE EASEMENTS, AND DETENTION FACILITIES WILL BE OWNED AND MAINTAINED BY THE HOA/POA. ANY COMMON AREAS WITHIN THE CITY'S RIGHT-OF-WAY ARE REQUIRED TO BE AN HOA "X" LOT.
- ALL COMMON AREA/HOA LOTS OR FLOODPLAIN MAY CONTAIN A PUBLIC TRAIL AND SHALL PROVIDE AN ACCESS EASEMENT FOR THE PUBLIC TO USE THE TRAIL.
- NOTICE - SELLING A PORTION OF THIS ADDITION BY METES AND BOUNDS IS A VIOLATION OF CITY ORDINANCE AND STATE LAW AND IS SUBJECT TO FINES AND WITHHOLDING OF UTILITIES AND BUILDING PERMITS.

- THIS PLAT DOES NOT ALTER OR REMOVE EXISTING DEED RESTRICTIONS, IF ANY, OF THIS PROPERTY.
- MINIMUM FINISHED FLOOR ELEVATIONS ARE AT LEAST 2 FEET ABOVE THE 100 YEAR FLOOD PLAN.
- THE SUBJECT PROPERTY DOES NOT LIE WITHIN A 100-YEAR FLOOD PLAN ACCORDING TO THE COMMUNITY PANEL NO. 4805C0110J AND 4805C0120J, REVISED JUNE 02, 2009, OF THE NATIONAL FLOOD INSURANCE RATE MAPS OF DENTON OR COLLIN COUNTY, TEXAS.
- NO OVERHEAD UTILITIES ARE PERMITTED ON THE SUBJECT PROPERTY.
- FOR EACH LOT THAT HAS A RETAINING WALL BUILT WITHIN THIS PLATTED AREA, A 3' WALL MAINTENANCE EASEMENT SHALL EXIST ON THE ADJOINING LOT. SEE TYPICAL WALL MAINTENANCE EASEMENT DETAIL.
- ALL CORNERS ARE SET WITH A 5/8" IRON ROD WITH YELLOW PLASTIC CAP STAMPED "LJA SURVEYING", UNLESS OTHERWISE NOTED.

DENSITY: 26%	LOT COUNT
40'x100'	50
50'x120'	133
60'x120'	73
TOTAL	256

LJA Surveying, Inc.
6060 North Central Expressway
Dallas, Texas 75206

Phone 469.621.0710
T.B.P.E.L.S. Firm No. 10194382

Date: APRIL 2024 JOB NO. 0058

OWNER:
WJ HILLSIDE LP
600 N. PEARL STREET, SUITE 2350
DALLAS, TEXAS 75201
PHONE: (214) 880-8619

STATE OF TEXAS, COUNTY OF COLLIN
I, STACEY KEMP, COUNTY CLERK OF COLLIN COUNTY,
DO HEREBY CERTIFY THAT THIS PLAT WAS FILED FOR RECORD IN
MY OFFICE AND DULY RECORDED IN THE PLAT RECORDS
OF COLLIN COUNTY ON: 04/04/2024 04:27 PM
PLAT BOOK: 2024 PAGE: 342 - 348
NUMBER OF PAGES: 2 AMOUNT: \$100.50
IN TESTIMONY WHEREOF, WITNESS MY HAND
AND OFFICIAL SEAL OF OFFICE,
COUNTY CLERK, COLLIN COUNTY, TEXAS

By: *Stacey Kemp* DEPUTY

LOT AREA TABLE with columns for LOT, BLOCK, ACRES, Sq.Ft., and sub-blocks (BLK A through BLK G).

Table with columns for LINE, BEARING, DISTANCE, and sub-blocks (BLK A through BLK G).

Table with columns for CURVE, CENTRAL ANGLE, RADIUS, CHORD BEARING, CHORD LENGTH, and ARC LENGTH.

OWNERS ACKNOWLEDGEMENT AND DEDICATION

STATE OF TEXAS COUNTY OF COLLIN WHEREAS WJ HILLSIDE, LP IS THE SOLE OWNER OF A 66.828 ACRE TRACT OF LAND SITUATED IN THE COLLIN COUNTY SCHOOL LAND SURVEY # 14, ABSTRACT NO. 167, CITY OF CELINA, COLLIN COUNTY, TEXAS, AND BEING PART OF A 71.336 ACRE TRACT OF LAND, CONVEYED TO WJ HILLSIDE, LP, AS RECORDED IN COUNTY CLERK'S FILE NO. 20211020227870, OFFICIAL PUBLIC RECORDS, COLLIN COUNTY, TEXAS, SAID 66.828 ACRE TRACT, WITH BEARING BEING GRAD, COLLIN COUNTY, TEXAS STATE PLANE COORDINATES, NORTH CENTRAL ZONE NAD83, (NAD83 (2011) EPOCH 2010), DETERMINED BY GPS OBSERVATIONS, CALCULATED FROM COLLIN CORNERS APP (PID-DP8982), AND DENTON CORNERS APP (PID-DP8986), BEING MORE PARTICULARLY DESCRIBED BY METES AND BOUNDS AS FOLLOWS:

BEGINNING AT A 1/2" IRON ROD FOUND FOR THE NORTHEAST CORNER OF SAID 71.336 ACRE TRACT AND THE COMMON SOUTHWEST CORNER OF A 9.851 ACRE TRACT OF LAND CONVEYED AS "TRACT Z", TO CELINA COMMERCIAL INVESTMENTS, L.L.C. AS RECORDED IN COUNTY CLERK'S FILE NO. 2019110101383990, OFFICIAL PUBLIC RECORDS, COLLIN COUNTY, TEXAS, SAID POINT BEING ON THE WEST LINE OF A 2.74 ACRE TRACT OF LAND CONVEYED TO ROBERT C. LORTICE, AS RECORDED IN COUNTY CLERK'S FILE NO. 1984040000314370, OFFICIAL PUBLIC RECORDS, COLLIN COUNTY, TEXAS AND BEING WITHIN KC ROBINSON LANE, (PRESCRIPTIVE RIGHT-OF-WAY);

THENCE, SOUTH 00 DEGREES 52 MINUTES 36 SECONDS EAST, ALONG THE EAST LINE OF SAID 71.336 ACRE TRACT AND THE COMMON WEST LINE SAID 2.74 ACRE TRACT, A 5.000 ACRE TRACT OF LAND CONVEYED TO MHN SQUARED, L.L.C. AS RECORDED IN COUNTY CLERK'S FILE NO. 20210100078490, OFFICIAL PUBLIC RECORDS, COLLIN COUNTY, TEXAS, A 6.000 ACRE TRACT OF LAND CONVEYED TO BILLY JOHN CARTER, JR. AND RITA S. CARTER, AS RECORDED IN COUNTY CLERK'S FILE NO. 1996041500037290, OFFICIAL PUBLIC RECORDS, COLLIN COUNTY, TEXAS, AND A 1.000 ACRE TRACT OF LAND CONVEYED TO BILLY JOHN CARTER, JR. AND RITA S. CARTER, AS RECORDED IN COUNTY CLERK'S FILE NO. 2008011200064370, OFFICIAL PUBLIC RECORDS, COLLIN COUNTY, TEXAS, A 5.000 ACRE TRACT OF LAND CONVEYED TO DALLA A. BRUTON AND TAMARA D. BRUTON, AS RECORDED IN COUNTY CLERK'S FILE NO. 2016090701318990, OFFICIAL PUBLIC RECORDS, COLLIN COUNTY, TEXAS, AND A 5.84 ACRE TRACT OF LAND CONVEYED TO PAUL A. DAVIS, AS RECORDED IN COUNTY CLERK'S FILE NO. 2004081900073290, OFFICIAL PUBLIC RECORDS, COLLIN COUNTY, TEXAS, AND A 5.84 ACRE TRACT OF LAND CONVEYED TO THE TRUSTEES OF THE BILMUDA COX MATUSEK SPECIAL TRUST, AS RECORDED IN COUNTY CLERK'S FILE NO. 2012072000091620 AND DESCRIBED IN VOLUME 1102, PAGE 761, DEED RECORDS, COLLIN COUNTY, TEXAS, WITH SAID KC ROBINSON LANE, A DISTANCE OF 1910.90 FEET TO A 5/8" IRON ROD WITH YELLOW PLASTIC CAP STAMPED "LJA SURVEYING" SET FOR CORNER, FROM WHICH A 5/8" IRON ROD FOUND FOR THE SOUTHEAST CORNER OF SAID 71.336 ACRE TRACT AND THE COMMON NORTHEAST CORNER OF A 7.774 ACRE TRACT OF LAND CONVEYED TO VERA LUCILLE JIMKS, AS RECORDED IN COUNTY CLERK'S FILE NO. 1982040000000000, OFFICIAL PUBLIC RECORDS, COLLIN COUNTY, TEXAS, BEARS SOUTH 00 DEGREES 52 MINUTES 36 SECONDS EAST, A DISTANCE OF 569.41 FEET;

THENCE, OVER AND ACROSS SAID 71.336 ACRE TRACT, THE FOLLOWING COURSES AND DISTANCES:

SOUTH 89 DEGREES 07 MINUTES 24 SECONDS WEST, A DISTANCE OF 50.00 FEET TO A 5/8" IRON ROD WITH YELLOW PLASTIC CAP STAMPED "LJA SURVEYING" SET FOR CORNER, AND THE BEGINNING OF A TANGENT CURVE TO THE RIGHT HAVING A CENTRAL ANGLE OF 06 DEGREES 00 MINUTES 00 SECONDS, A RADIUS OF 380.00 FEET, AND A LONG CHORD THAT BEARS SOUTH 07 DEGREES 52 MINUTES 36 SECONDS WEST, A DISTANCE OF 39.78 FEET;

ALONG SAID TANGENT CURVE TO THE RIGHT, AN ARC DISTANCE OF 36.78 FEET TO A 5/8" IRON ROD WITH YELLOW PLASTIC CAP STAMPED "LJA SURVEYING" SET FOR CORNER;

NORTH 84 DEGREES 52 MINUTES 36 SECONDS WEST, A DISTANCE OF 3.42 FEET TO A 5/8" IRON ROD WITH YELLOW PLASTIC CAP STAMPED "LJA SURVEYING" SET FOR CORNER;

SOUTH 47 DEGREES 07 MINUTES 24 SECONDS WEST, A DISTANCE OF 33.46 FEET TO A 5/8" IRON ROD WITH YELLOW PLASTIC CAP STAMPED "LJA SURVEYING" SET FOR CORNER;

SOUTH 00 DEGREES 52 MINUTES 36 SECONDS EAST, A DISTANCE OF 61.42 FEET TO A 5/8" IRON ROD WITH YELLOW PLASTIC CAP STAMPED "LJA SURVEYING" SET FOR CORNER;

SOUTH 00 DEGREES 52 MINUTES 36 SECONDS EAST, A DISTANCE OF 18.00 FEET TO A 5/8" IRON ROD WITH YELLOW PLASTIC CAP STAMPED "LJA SURVEYING" SET FOR CORNER;

SOUTH 17 DEGREES 33 MINUTES 30 SECONDS WEST, A DISTANCE OF 15.81 FEET TO A 5/8" IRON ROD WITH YELLOW PLASTIC CAP STAMPED "LJA SURVEYING" SET FOR CORNER;

SOUTH 00 DEGREES 52 MINUTES 36 SECONDS EAST, A DISTANCE OF 291.96 FEET TO A 5/8" IRON ROD WITH YELLOW PLASTIC CAP STAMPED "LJA SURVEYING" SET FOR CORNER, AND THE BEGINNING OF A TANGENT CURVE TO THE RIGHT HAVING A CENTRAL ANGLE OF 111 DEGREES 47 MINUTES 12 SECONDS, A RADIUS OF 800.00 FEET, AND A LONG CHORD THAT BEARS SOUTH 55 DEGREES 01 MINUTE 01 SECOND WEST, A DISTANCE OF 62.90 FEET;

ALONG SAID TANGENT CURVE TO THE RIGHT, AN ARC DISTANCE OF 67.55 FEET TO A 5/8" IRON ROD WITH YELLOW PLASTIC CAP STAMPED "LJA SURVEYING" SET FOR CORNER, AND THE BEGINNING OF A REVERSE CURVE TO THE LEFT HAVING A CENTRAL ANGLE OF 21 DEGREES 47 MINUTES 12 SECONDS, A RADIUS OF 20.00 FEET, AND A LONG CHORD THAT BEARS NORTH 79 DEGREES 58 MINUTES 59 SECONDS WEST, A DISTANCE OF 7.61 FEET;

ALONG SAID REVERSE CURVE TO THE LEFT, AN ARC DISTANCE OF 7.61 FEET TO A 5/8" IRON ROD WITH YELLOW PLASTIC CAP STAMPED "LJA SURVEYING" SET FOR CORNER;

SOUTH 89 DEGREES 07 MINUTES 24 SECONDS WEST, A DISTANCE OF 69.02 FEET TO A 5/8" IRON ROD WITH YELLOW PLASTIC CAP STAMPED "LJA SURVEYING" SET FOR CORNER;

SOUTH 70 DEGREES 41 MINUTES 19 SECONDS WEST, A DISTANCE OF 15.81 FEET TO A 5/8" IRON ROD WITH YELLOW PLASTIC CAP STAMPED "LJA SURVEYING" SET FOR CORNER;

SOUTH 89 DEGREES 07 MINUTES 24 SECONDS WEST, A DISTANCE OF 18.00 FEET TO A 5/8" IRON ROD WITH YELLOW PLASTIC CAP STAMPED "LJA SURVEYING" SET FOR CORNER;

NORTH 72 DEGREES 26 MINUTES 30 SECONDS WEST, A DISTANCE OF 15.81 FEET TO A 5/8" IRON ROD WITH YELLOW PLASTIC CAP STAMPED "LJA SURVEYING" SET FOR CORNER;

SOUTH 89 DEGREES 07 MINUTES 24 SECONDS WEST, A DISTANCE OF 543.77 FEET TO A 5/8" IRON ROD WITH YELLOW PLASTIC CAP STAMPED "LJA SURVEYING" SET FOR CORNER, AND THE BEGINNING OF A TANGENT CURVE TO THE RIGHT HAVING A CENTRAL ANGLE OF 14 DEGREES 50 MINUTES 23 SECONDS, A RADIUS OF 625.00 FEET, AND A LONG CHORD THAT BEARS SOUTH 78 DEGREES 55 MINUTES 49 SECONDS WEST, A DISTANCE OF 136.60 FEET;

ALONG SAID TANGENT CURVE TO THE RIGHT, AN ARC DISTANCE OF 136.98 FEET TO A 5/8" IRON ROD WITH YELLOW PLASTIC CAP STAMPED "LJA SURVEYING" SET FOR CORNER, AND THE BEGINNING OF A REVERSE CURVE TO THE LEFT HAVING A CENTRAL ANGLE OF 50 DEGREES 04 MINUTES 05 SECONDS, A RADIUS OF 20.00 FEET, AND A LONG CHORD THAT BEARS SOUTH 78 DEGREES 55 MINUTES 49 SECONDS WEST, A DISTANCE OF 16.93 FEET;

ALONG SAID REVERSE CURVE TO THE LEFT, AN ARC DISTANCE OF 17.48 FEET TO A 5/8" IRON ROD WITH YELLOW PLASTIC CAP STAMPED "LJA SURVEYING" SET FOR CORNER;

SOUTH 53 DEGREES 53 MINUTES 46 SECONDS WEST, A DISTANCE OF 31.15 FEET TO A 5/8" IRON ROD WITH YELLOW PLASTIC CAP STAMPED "LJA SURVEYING" SET FOR CORNER;

SOUTH 84 DEGREES 49 MINUTES 28 SECONDS WEST, A DISTANCE OF 18.14 FEET TO A 5/8" IRON ROD WITH YELLOW PLASTIC CAP STAMPED "LJA SURVEYING" SET FOR CORNER;

NORTH 61 DEGREES 40 MINUTES 34 SECONDS WEST, A DISTANCE OF 16.50 FEET TO A 5/8" IRON ROD WITH YELLOW PLASTIC CAP STAMPED "LJA SURVEYING" SET FOR CORNER, AND THE BEGINNING OF A NON-TANGENT CURVE TO THE RIGHT HAVING A CENTRAL ANGLE OF 30 DEGREES 54 MINUTES 13 SECONDS, A RADIUS OF 60.00 FEET, AND A LONG CHORD THAT BEARS NORTH 25 DEGREES 07 MINUTES 24 SECONDS WEST, A DISTANCE OF 07.69 FEET;

ALONG SAID NON-TANGENT CURVE TO THE RIGHT, AN ARC DISTANCE OF 98.34 FEET TO A 5/8" IRON ROD WITH YELLOW PLASTIC CAP STAMPED "LJA SURVEYING" SET FOR CORNER;

SOUTH 21 DEGREES 48 MINUTES 32 SECONDS WEST, A DISTANCE OF 218.12 FEET TO A 5/8" IRON ROD WITH YELLOW PLASTIC CAP STAMPED "LJA SURVEYING" SET FOR CORNER ON THE SOUTH LINE OF SAID 71.336 ACRE TRACT AND THE COMMON NORTH LINE OF SAID 71.336 ACRE TRACT, SAID POINT BEING WITHIN E. GLENDENING PARKWAY, (PRESCRIPTIVE RIGHT-OF-WAY);

THENCE, SOUTH 88 DEGREES 22 MINUTES 07 SECONDS WEST, ALONG SAID COMMON LINE, A DISTANCE OF 76.31 FEET TO A 3/8" IRON ROD FOUND, (BENT) FOR THE SOUTHWEST CORNER OF SAID 71.336 ACRE TRACT AND THE COMMON SOUTHWEST CORNER OF A 2.000 ACRE TRACT OF LAND CONVEYED TO SUMMIT CENTER AT PRESTON, LLC, AS RECORDED IN COUNTY CLERK'S FILE NO. 2013070800094590, OFFICIAL PUBLIC RECORDS, COLLIN COUNTY, TEXAS;

THENCE, NORTH 00 DEGREES 54 MINUTES 57 SECONDS WEST, ALONG THE WEST LINE OF SAID 71.336 ACRE TRACT AND THE COMMON EAST LINE OF SAID 20.000 ACRE TRACT, THE EAST LINE OF A 16.887 ACRE TRACT OF LAND CONVEYED TO JEOU-SHYONG HUANG AND MEI-FU LIN HUANG, AS RECORDED IN COUNTY CLERK'S FILE NO. 2012070300080140, OFFICIAL PUBLIC RECORDS, COLLIN COUNTY, TEXAS, THE EAST LINE OF A 4.321 ACRE TRACT OF LAND CONVEYED TO PRESTON TERP, L.L.C., AS RECORDED IN COUNTY CLERK'S FILE NO. 2020031100035690, OFFICIAL PUBLIC RECORDS, COLLIN COUNTY, TEXAS, THE EAST LINE OF LOT 1, BLOCK A OF THE KELLER WILLIAMS ADDITION, PHASE 1, AN ADDITION TO THE CITY OF CELINA, AS RECORDED IN COUNTY CLERK'S FILE NO. 2019041201001010 AND IN CABINET 2019, PAGE 291, OFFICIAL PUBLIC RECORDS, COLLIN COUNTY, TEXAS, AND THE EAST LINE OF A 3.50 ACRE TRACT OF LAND CONVEYED TO AL-RAZA ENTERPRISES INC., AS RECORDED IN COUNTY CLERK'S FILE NO. 2008031200026980, OFFICIAL PUBLIC RECORDS, COLLIN COUNTY, TEXAS, A DISTANCE OF 2486.66 FEET A 1/2" IRON ROD WITH CAP STAMPED "SHIELDS" FOUND FOR THE NORTHWEST CORNER OF SAID 71.336 ACRE TRACT AND THE COMMON NORTHEAST CORNER OF SAID 3.50 ACRE TRACT, SAID POINT BEING ON THE SOUTH LINE OF LOT 3R-1, BLOCK A OF THE REPLAT OF CELINA TOWN CENTER ADDITION-PHASE 2, AN ADDITION TO THE CITY OF CELINA, AS RECORDED IN COUNTY CLERK'S FILE NO. 2014031201000780, AND IN CABINET 2014, PAGE 117, AND IN SLIDE 9415-1, PLAT RECORDS, COLLIN COUNTY, TEXAS;

THENCE, NORTH 89 DEGREES 09 MINUTES 16 SECONDS EAST, ALONG THE NORTH LINE OF SAID 71.336 ACRE TRACT AND THE COMMON SOUTH LINE OF SAID LOT 3R-1, BLOCK A, THE SOUTH LINE OF LOT 6, BLOCK A OF CELINA TOWN CENTER ADDITION, PHASE 2, AN ADDITION TO THE CITY OF CELINA, AS RECORDED IN COUNTY CLERK'S FILE NO. 20070803010002810, IN CABINET 2007, PAGE 393, AND IN SLIDE 9415, PLAT RECORDS, COLLIN COUNTY, TEXAS, AND THE SOUTH LINE OF AFORESAID 9.831 ACRE TRACT, A DISTANCE OF 1237.55 FEET TO THE POINT OF BEGINNING AND CONTAINING A CALCULATED AREA OF 66.828 ACRES OF LAND.

ALONG SAID TANGENT CURVE TO THE RIGHT, AN ARC DISTANCE OF 97.55 FEET TO A 5/8" IRON ROD WITH YELLOW PLASTIC CAP STAMPED "LJA SURVEYING" SET FOR CORNER, AND THE BEGINNING OF A REVERSE CURVE TO THE LEFT HAVING A CENTRAL ANGLE OF 21 DEGREES 47 MINUTES 12 SECONDS, A RADIUS OF 20.00 FEET, AND A LONG CHORD THAT BEARS NORTH 79 DEGREES 58 MINUTES 59 SECONDS WEST, A DISTANCE OF 7.61 FEET;

ALONG SAID REVERSE CURVE TO THE LEFT, AN ARC DISTANCE OF 7.61 FEET TO A 5/8" IRON ROD WITH YELLOW PLASTIC CAP STAMPED "LJA SURVEYING" SET FOR CORNER;

SOUTH 89 DEGREES 07 MINUTES 24 SECONDS WEST, A DISTANCE OF 69.02 FEET TO A 5/8" IRON ROD WITH YELLOW PLASTIC CAP STAMPED "LJA SURVEYING" SET FOR CORNER;

SOUTH 89 DEGREES 07 MINUTES 24 SECONDS WEST, A DISTANCE OF 69.02 FEET TO A 5/8" IRON ROD WITH YELLOW PLASTIC CAP STAMPED "LJA SURVEYING" SET FOR CORNER;

SOUTH 89 DEGREES 07 MINUTES 24 SECONDS WEST, A DISTANCE OF 69.02 FEET TO A 5/8" IRON ROD WITH YELLOW PLASTIC CAP STAMPED "LJA SURVEYING" SET FOR CORNER;

SOUTH 89 DEGREES 07 MINUTES 24 SECONDS WEST, A DISTANCE OF 69.02 FEET TO A 5/8" IRON ROD WITH YELLOW PLASTIC CAP STAMPED "LJA SURVEYING" SET FOR CORNER;

SOUTH 89 DEGREES 07 MINUTES 24 SECONDS WEST, A DISTANCE OF 69.02 FEET TO A 5/8" IRON ROD WITH YELLOW PLASTIC CAP STAMPED "LJA SURVEYING" SET FOR CORNER;

SOUTH 89 DEGREES 07 MINUTES 24 SECONDS WEST, A DISTANCE OF 69.02 FEET TO A 5/8" IRON ROD WITH YELLOW PLASTIC CAP STAMPED "LJA SURVEYING" SET FOR CORNER;

SOUTH 89 DEGREES 07 MINUTES 24 SECONDS WEST, A DISTANCE OF 69.02 FEET TO A 5/8" IRON ROD WITH YELLOW PLASTIC CAP STAMPED "LJA SURVEYING" SET FOR CORNER;

SOUTH 89 DEGREES 07 MINUTES 24 SECONDS WEST, A DISTANCE OF 69.02 FEET TO A 5/8" IRON ROD WITH YELLOW PLASTIC CAP STAMPED "LJA SURVEYING" SET FOR CORNER;

SOUTH 89 DEGREES 07 MINUTES 24 SECONDS WEST, A DISTANCE OF 69.02 FEET TO A 5/8" IRON ROD WITH YELLOW PLASTIC CAP STAMPED "LJA SURVEYING" SET FOR CORNER;

SOUTH 89 DEGREES 07 MINUTES 24 SECONDS WEST, A DISTANCE OF 69.02 FEET TO A 5/8" IRON ROD WITH YELLOW PLASTIC CAP STAMPED "LJA SURVEYING" SET FOR CORNER;

SOUTH 89 DEGREES 07 MINUTES 24 SECONDS WEST, A DISTANCE OF 69.02 FEET TO A 5/8" IRON ROD WITH YELLOW PLASTIC CAP STAMPED "LJA SURVEYING" SET FOR CORNER;

SOUTH 89 DEGREES 07 MINUTES 24 SECONDS WEST, A DISTANCE OF 69.02 FEET TO A 5/8" IRON ROD WITH YELLOW PLASTIC CAP STAMPED "LJA SURVEYING" SET FOR CORNER;

SOUTH 89 DEGREES 07 MINUTES 24 SECONDS WEST, A DISTANCE OF 69.02 FEET TO A 5/8" IRON ROD WITH YELLOW PLASTIC CAP STAMPED "LJA SURVEYING" SET FOR CORNER;

SOUTH 89 DEGREES 07 MINUTES 24 SECONDS WEST, A DISTANCE OF 69.02 FEET TO A 5/8" IRON ROD WITH YELLOW PLASTIC CAP STAMPED "LJA SURVEYING" SET FOR CORNER;

SOUTH 89 DEGREES 07 MINUTES 24 SECONDS WEST, A DISTANCE OF 69.02 FEET TO A 5/8" IRON ROD WITH YELLOW PLASTIC CAP STAMPED "LJA SURVEYING" SET FOR CORNER;

SOUTH 89 DEGREES 07 MINUTES 24 SECONDS WEST, A DISTANCE OF 69.02 FEET TO A 5/8" IRON ROD WITH YELLOW PLASTIC CAP STAMPED "LJA SURVEYING" SET FOR CORNER;

SOUTH 89 DEGREES 07 MINUTES 24 SECONDS WEST, A DISTANCE OF 69.02 FEET TO A 5/8" IRON ROD WITH YELLOW PLASTIC CAP STAMPED "LJA SURVEYING" SET FOR CORNER;

SOUTH 89 DEGREES 07 MINUTES 24 SECONDS WEST, A DISTANCE OF 69.02 FEET TO A 5/8" IRON ROD WITH YELLOW PLASTIC CAP STAMPED "LJA SURVEYING" SET FOR CORNER;

SOUTH 89 DEGREES 07 MINUTES 24 SECONDS WEST, A DISTANCE OF 69.02 FEET TO A 5/8" IRON ROD WITH YELLOW PLASTIC CAP STAMPED "LJA SURVEYING" SET FOR CORNER;

SOUTH 89 DEGREES 07 MINUTES 24 SECONDS WEST, A DISTANCE OF 69.02 FEET TO A 5/8" IRON ROD WITH YELLOW PLASTIC CAP STAMPED "LJA SURVEYING" SET FOR CORNER;

SOUTH 89 DEGREES 07 MINUTES 24 SECONDS WEST, A DISTANCE OF 69.02 FEET TO A 5/8" IRON ROD WITH YELLOW PLASTIC CAP STAMPED "LJA SURVEYING" SET FOR CORNER;

SOUTH 89 DEGREES 07 MINUTES 24 SECONDS WEST, A DISTANCE OF 69.02 FEET TO A 5/8" IRON ROD WITH YELLOW PLASTIC CAP STAMPED "LJA SURVEYING" SET FOR CORNER;

NOW, THEREFORE, KNOW ALL PERSONS BY THESE PRESENTS: THAT WJ HILLSIDE, LP, ACTING HEREIN BY AND THROUGH ITS DULY AUTHORIZED OFFICER, DOES HEREBY ADOPT THIS FINAL PLAT DESIGNATING THE HERETOFORE DESCRIBED PROPERTY AS HILLSIDE VILLAGE, PHASE 1A, AN ADDITION TO THE CITY OF CELINA, TEXAS, AND DOES HEREBY DEDICATE TO THE PUBLIC USE FOREVER, ALL STREETS, THROUGHFARES, ALLEYS, FIRE LANES, DRIVE AISLES, PARKING SPACES, PARKS, AND TRAILS, AND TO THE PUBLIC USE FOREVER, EASEMENTS FOR SIDEWALKS, STORM DRAINAGE FACILITIES, FLOODWAYS, WATER MAINS, WASTEWATER MAINS, AND OTHER UTILITIES AND FACILITIES, AND ANY OTHER PROPERTY NECESSARY TO SERVE THE PLAT AND TO IMPLEMENT THE REQUIREMENTS OF THE SUBDIVISION REGULATIONS AND OTHER CITY CODES AND DO HEREBY BIND OURSELVES, OUR HEIRS, SUCCESSORS AND ASSIGNS TO WARRANT AND TO FOREVER DEFEND THE TITLE ON THE LAND SO DEDICATED. FURTHER, THE UNDERSIGNED COVENANTS AND AGREES THAT HE/SHE SHALL MAINTAIN ALL EASEMENTS AND FACILITIES IN A STATE OF GOOD REPAIR AND FUNCTIONAL CONDITION AT ALL TIMES IN ACCORDANCE WITH CITY CODES AND REGULATIONS. NO BUILDINGS, FENCES, TREES, SHRUBS, OR OTHER IMPROVEMENTS OR GROWTHS SHALL BE CONSTRUCTED OR PLACED UPON, OVER, OR ACROSS THE EASEMENTS AS SHOWN, EXCEPT THAT LANDSCAPE IMPROVEMENTS MAY BE INSTALLED, IF APPROVED BY THE CITY OF CELINA, AT NO POINT SHALL ANY OVERHEAD UTILITIES BE INSTALLED ON THE SUBJECT PROPERTY. THE CITY OF CELINA AND PUBLIC UTILITY ENTITIES SHALL HAVE THE RIGHT TO ACCESS AND MAINTAIN ALL RESPECTIVE EASEMENTS WITHOUT THE NECESSITY AT ANY TIME OF PROCURING PERMISSION FROM ANYONE.

WITNESS MY HAND, THIS 4th DAY OF April, A.D. 2024. OWNER: WJ HILLSIDE LP, A TEXAS LIMITED PARTNERSHIP

BY: WJ HILLSIDE LP, A TEXAS LIMITED LIABILITY COMPANY, ITS GENERAL MANAGER Christopher J. Johnson, TITLE: Vice President

STATE OF TEXAS COUNTY OF COLLIN

BEFORE ME, THE UNDERSIGNED AUTHORITY IN AND FOR COLLIN COUNTY, TEXAS, ON THIS DAY PERSONALLY APPEARED [Name], KNOWN TO ME TO BE THE PERSON AND OFFICER WHOSE NAME IS SUBSCRIBED TO THE FOREGOING INSTRUMENT AND ACKNOWLEDGED TO ME THAT HE/SHE IS THE PERSON WHOSE NAME IS SUBSCRIBED TO THE FOREGOING INSTRUMENT AND THAT HE/SHE IS AUTHORIZED TO EXECUTE THE FOREGOING INSTRUMENT FOR THE PURPOSES AND CONSIDERATION THEREIN EXPRESSED, AND IN THE CAPACITY THEREIN STATED.

GIVEN UNDER MY HAND AND SEAL OF OFFICE, THIS 4th DAY OF April, 2024.

NOTARY PUBLIC IN AND FOR THE STATE OF TEXAS Melissa A. Doherty, My Commission Expires: 2-22-2028

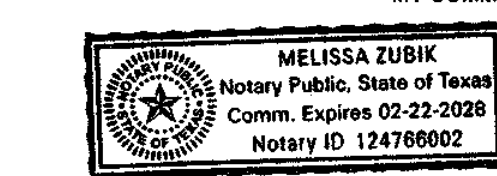

CERTIFICATE OF PLAT APPROVAL

APPROVED [Signature] 4-4-24 DATE CITY DEVELOPMENT OFFICIAL CITY OF CELINA, TEXAS

WITNESS BY HAND THIS 4th DAY OF April, 2024 [Signature] CITY SECRETARY CITY OF CELINA, TEXAS



A FINAL PLAT OF HILLSIDE VILLAGE, PHASE 1A

OUT OF THE COLLIN COUNTY SCHOOL LAND SURVEY NO. 14, ABSTRACT NO. 167

IN THE CITY OF CELINA, COLLIN COUNTY, TEXAS

66.828 ACRES 256 RESIDENTIAL LOTS 11 OPEN SPACE/HOA LOTS

OWNER: WJ HILLSIDE LP, 600 N. PEARL STREET, SUITE 2350, DALLAS, TEXAS 75201, PHONE: (214) 880-8619

STATE OF TEXAS, COUNTY OF COLLIN I, STACEY KEMP, COUNTY CLERK OF COLLIN COUNTY, DO HEREBY CERTIFY THAT THIS PLAT WAS FILED FOR RECORD IN MY OFFICE AND DULY RECORDED IN THE PLAT RECORDS OF COLLIN COUNTY ON 04/04/2024 04:27 PM

PLAT BOOK: 2024 PAGE: 342 - 349 NUMBER OF PAGES: 2 AMOUNT: \$100.50 IF TESTIMONY WHEREOF, WITNESS MY HAND AND OFFICIAL SEAL OF OFFICE, COUNTY CLERK, COLLIN COUNTY, TEXAS

BY: [Signature] DEPUTY

DATE: APRIL 2024 JOB NO. 0058

LJA Surveying, Inc. 6060 North Central Expressway Suite 400 Dallas, Texas 75206 T.B.P.E.L.S. Firm No. 10194382

HILLSIDE VILLAGE, PHASE 1A